

**TOUCH SAFE LOOP HEATER 50-150W -
LT 065**

LT

06500.0-00

LT 065, 50W Touch safe loop heater, 110V-265V ac/dc

- Low surface temperature
- Shock and vibration proof
- Wide voltage range
- Double insulated
- Pressure clamp connections

**PRODUCT DESCRIPTION**

Improved heating power to volume and temperature distribution than standard heaters, thanks to the new loop design.

50% quicker installation time due to pressure clamp terminals.

Vibration-proof for harsh conditions, e.g. High vibration impact in environments such as transport or wind power

Certified for use in the rail industry

TECHNICAL DATA**GENERAL DATA**

Colour	Black, White
Heat source	Self-regulating PTC-element
Nominal voltage	120-240 V AC/DC
Connection type	2-pole terminal 2.5mm ²
Recommended fuse (slow blow)	6 A
Starting current max	4 A
Heat output	50 W
Mounting	DIN-rail 35mm
Heater body	Plastic

DIMENSIONS

Weight	0,4 kg
---------------	--------

Depth	140 mm
Width	57 mm
Height	101 mm

SAFETY & APPROVALS

IP class	IP20
Protection class	II (double insulated)
Approvals	RoHS 3, CE, UKCA, cRUus, EAC, UL E234324, VDE

RATED OPERATING CONDITIONS

Operational temperature	-45°C ... +70°C
Temperature 50 mm above the heater	<+80°C (+176°F)
Storage temperature	-45°C ... +70°C
Humidity storage	<90% RH
Operating humidity	<90% RH
Voltage min	110 V ac/dc
Voltage max	265 V ac/dc
Housing	Plastic enclosure, UL94 V-0

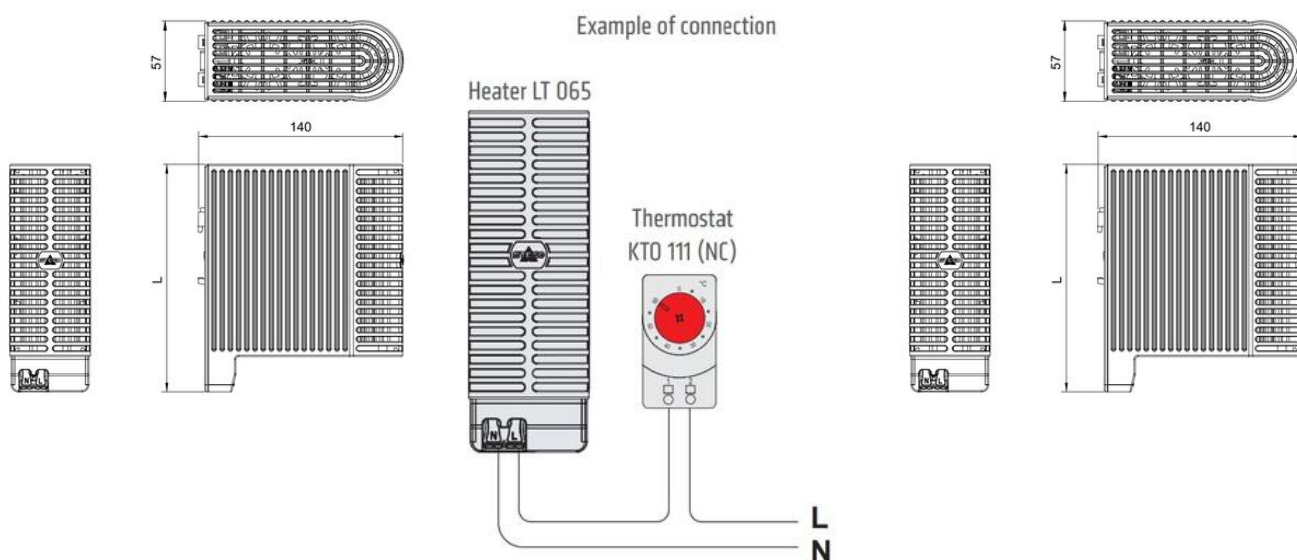

Example of connection

Heater LT 065



Thermostat
KTO 111 (NC)

