

HONSBERG - UR1 SERIES FLOW SWITCH

Paddle

UR1-010GM

- Switching range 1,3..35 l/min
- Water (oils, gases and aggressive media available on request)
- G $\frac{3}{8}$ " up to G2"
- Brass or stainless steel wetted parts
- Max pressure 25 bar



PRODUCT DESCRIPTION

The Honsberg UR1 is a simple flow switch which can easily be adjusted and also changed from normally open to normally closed. The flow switch works via a spring-supported paddle which moves according to the flow and when the specific flow is reached a magnetic reed switch is activated.

SPECIAL VERSIONS

- Plastic materials
- Weld/solder connection
- High volume OEM version
- Ex
- Switching ranges for oil or gas
- Special values
- High volume OEM version
- PVC (solder fitting)

Ordering information

- Specify direction of flow, medium, and switching range, UR1 or switching value UR2.
- For UR2 specify normally closed (n.c.) or normally open (n.o.).
- For oils, state viscosity, temperature and designation (e.g. ISO VG 68) (enquire about range).
- For gases, state pressure (relative or absolute), temperature and medium (e.g. air) (enquire about range).

Installation

- Include straight calming section of 5 x DN in inlet and outlet.
- Include a filter if the media is dirty (use magnetic filter for ferritic components).
- It must be ensured that the values given for voltage, current and power are not exceeded.
- When switched on, a load must be connected in series.
- The electrical details apply to ohmic loads. Capacitive, inductive and lamp loads must be operated using a protective circuit.
- Standard: horizontal inwards flow; switching head not recommended underneath; other installation positions are possible; the installation position affects the switching point and range.

TECHNICAL DATA

Accuracy	±15% fs
Adjustable switching point l/min water	2,5..3,5 l/min
Connection type	G3/8" female
Contact rating max	50 A
Electrical connection	1.5m cable
Flow max	10 l/min
Function	Normally open or normally closed (SPST)
IP class	IP65
Material breaker body	Hard ferrite
Material of body	Nickel-plated brass, Stainless steel 303
Material of connection	Nickel-plated brass
Material of seals	NBR
Material of wetted parts	Nickel-plated brass, Stainless steel, Hard ferrite, NBR
Material paddle	Stainless steel 301
Media	Water (oil, air and aggressive media on request)
Pressure drop	Approx. 0.01 bar at max. flow
Pressure range max	25 bar
Temperature of media from	20 °C
Temperature of media to	110 °C
Type of flow component	Flow Switches
Weight	0,35 kg
Viscosity	1 cSt
Voltage ac max	230 V

Adjustment

UR1 - loosen bolts, push the switching current tube into the desired position. Retighten the bolts.
Normally closed (n.c.) or normally open (n.o.) as per table "Technical data"

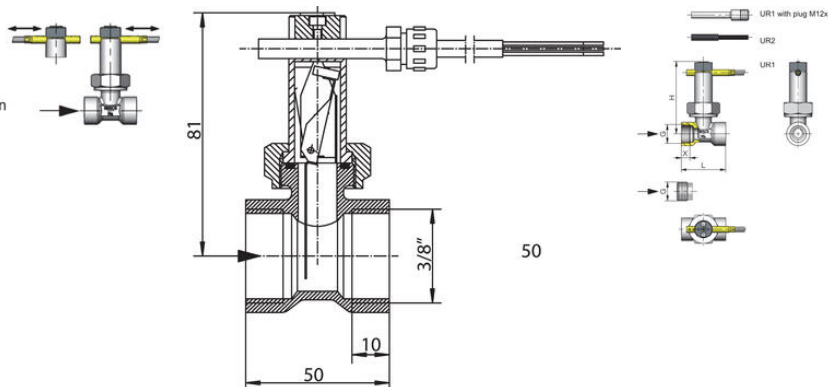

Dimensions and weights						
G	Types	H	L	X	Weight kg	
G 1/2	UR-010GM	82	50	10	UR1	UR2
	UR-010GK				0.35	0.35
G 1/2 A	UR-015AM		60	12	0.40	0.40
	UR-015AP				0.35	0.30
G 1/2	UR-015GM		50	10	0.15	0.15
	UR-015GK				0.35	0.30
G 1/4	UR-020GM	83			0.40	0.40
	UR-020GK		12		0.35	0.35
G 1	UR-020GM	87			0.45	0.45
	UR-020GK				0.40	0.40
G 1 1/2	UR-030GM	91			0.50	0.50
	UR-030GK				0.55	0.55
G 2	UR-040GM	94			0.65	0.65
	UR-040GK				0.65	0.75
G 2	UR-050GM	103			0.85	0.95
	UR-050GK				0.95	0.95

Adjustment

UR1 - loosen bolts, push the switching current tube into the desired position. Retighten the bolts.
Normally closed (n.c.) or normally open (n.o.) as per table "Technical data"

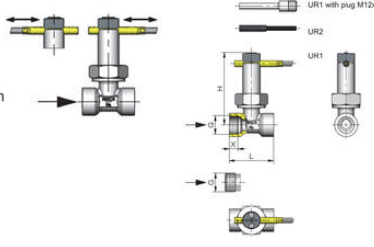

Dimensions and weights

G	Types	H	L	X	Weight	
					UR1	UR2
G 1/4	UR -010GM	82	50	10	0.35	0.30
	UR -010GK				0.40	0.40
	UR -015AM				0.35	0.30
G 1/2 A	UR -015AM	60	12	10	0.15	0.15
	UR -015AP				0.35	0.30
G 1/2	UR -015GM	50	10	10	0.40	0.40
	UR -015GK				0.35	0.35
G 3/4	UR -020GM	83	12	12	0.40	0.40
	UR -020GK				0.45	0.45
	UR -025GM				0.50	0.50
G 1	UR -025GK	87	12	12	0.45	0.45
	UR -032GM				0.50	0.50
G 1 1/2	UR -032GK	91	12	12	0.55	0.55
	UR -040GM				0.80	0.75
G 1 1/2	UR -040GK	94	12	12	0.85	0.85
	UR -050GM				0.80	0.75
G 2	UR -050GK	103	12	12	0.95	0.95
	UR -050GK				0.85	0.85