

LOCC-BOX-MINI 1-8 A

Electronic load monitoring up to DC 8 A

716480

- Adjustable current range: DC 1-8 A
- Single-channel design
- Included negative connection
- Adjustable characteristics
- Suitable for tight spaces



PRODUCT DESCRIPTION

Lutze's electronic circuit breaker range is being expanded with the new LOCC-Box-Mini. The LOCC-Box-Mini has an integrated negative connection, which makes it very flexible in tight spaces. It has a capacity of 1-8A(1A intervals) and 5 selectable characteristics: Fast (1), Medium (2), slow 1 (3), slow 2 (4), slow 3 (5). It is also adapted for 12/24V DC applications and provides both alarms for tripped fuses with a manual shutdown.

INTEGRATED NEGATIVE CONNECTION

The LOCC-Box-Mini has an integrated negative connection which there is a + and - directly on the fuse. This saves both space on the DIN rail and time during installation.

LUTZE'S RELIABLE ELECTRONIC CIRCUIT BREAKER

Lutze offers an electronic circuit breaker for 12 or 24 V DC systems that overcomes issues commonly associated with traditional miniature circuit breakers, particularly over long cable distances and with thin cable cross-sections. Lutze electronic circuit breakers ensure reliable tripping and selectivity without interruptions in unaffected groups. It allows users to adjust the rated current through a thumbwheel under a safety hatch. This adjustment should only be made when the fuse is switched off to prevent electrical hazards.

There are five different characteristics which can be selected to tailor the response to different load conditions, including high inrush currents. Even with the slowest settings the fuse reacts quickly to short circuits compared to a standard miniature circuit breaker.

ADJUSTABLE PARAMETERS AND FLEXIBLE LOAD RESPONSE

For easy connection, the 12 or 24 V DC input can be made directly into each fuse or via a power terminal with a copper rail, which is recommended for installation with multiple fuses mounted close together. A sliding plate mechanism enables easy connection to or isolation from the rail. The circuit breaker can be reset either manually with a button on the front panel or remotely. When a fault occurs, the LED indicator flashes red and when the fault is resolved, it turns solid red. A second reset signal activates the fuse, and the LED lights up green. Also, there is a signal output (open collector) that can be connected to a group providing an alarm in case any fuse in that group trips. The circuit breaker offers a safe system even in the event of electronic failures, thanks to features like a malfunction indicator and internal fuses.

ADVANCED FEATURES FOR SAFE AND EFFICIENT OPERATION

The signal output from the circuit breaker is an open collector type with a pull-up resistor. It allows for the grouping of fuses and alarms to receive notifications when any fuse in the group trips. The output voltage may vary depending on the external load resistance, Lutze recommends their interface relays for connecting relay coils to the alarm output, ensuring proper function and activation in case of a fault. Additionally, the circuit breaker includes built-in safety features, such as rapid malfunction indicator and an internal fuse to disconnect loads in the event of a short circuit during a fault, ensuring a secure

system even during electronic failures.

TECHNICAL DATA

INPUT DATA

Input current max	8 A
Operating voltage dc min	10 V
Operating voltage dc max	30 V

OUTPUT DATA

Adjustable current min	1 A
Output semiconductors	Mosfet
Voltage drop over semiconductor	180 mV
Capacitance max	10000 μ F
Output current max	8 A
Selectable current ranges	1-10A, adjustable in 1A steps
Reaction time	800 ms
Adjustable steps	1 A
Adjustable current max	8 A
Status indication	LED. Steady green - OK, flashing green - load over 90%, flashing red - fuse triggered, steady red - fuse off

DIMENSIONS

Depth	92 mm
Width	8,1 mm
Height	87 mm

CONNECTION DATA

IP class	IP20
Connection type	Spring 0.25-2.5mm ²
Cross section max	2,5 mm ²
Mounting	DIN-rail
Cross section min	0,25 mm ²

APPROVALS

Approvals	CE
EMC	EN61000-6-2, EN61000-6-4

ADDITIONAL DATA

Temperature operational max

50 °C

Weight

60 g

Memory at power failure

Yes, status retained when voltage is back on

Temperature operational min

-25 °C

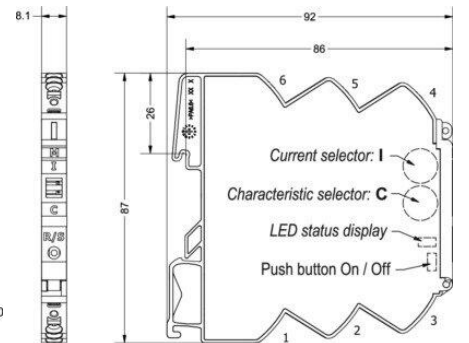
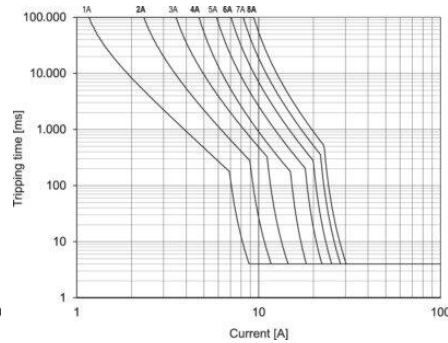
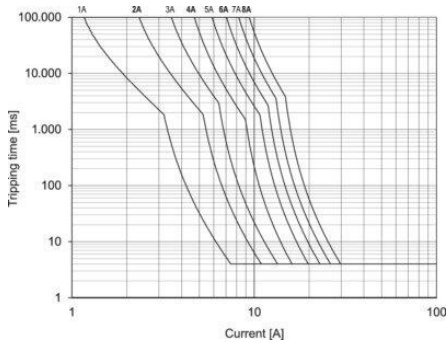
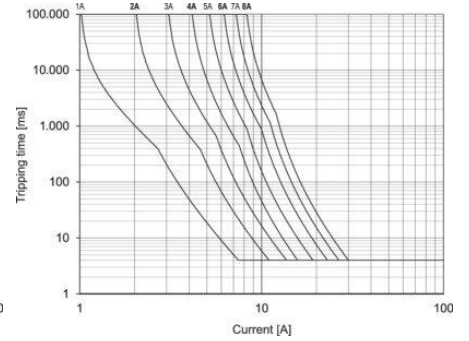
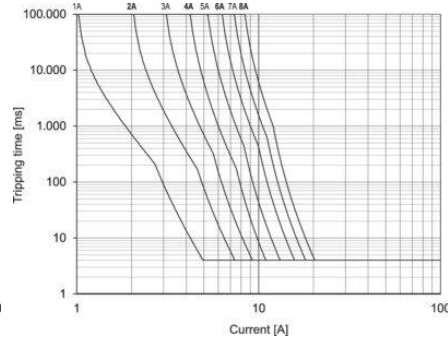
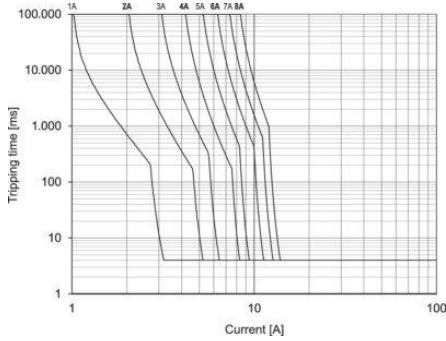

Input side

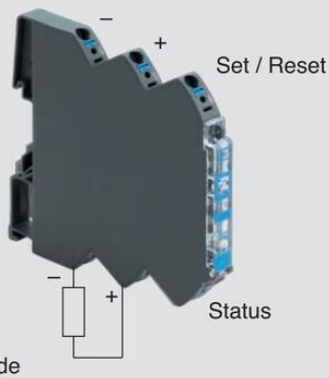

Output side

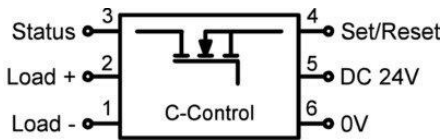

- 1: Load -
- 2: Load +
- 3: Status output
- 4: Set/Reset
- 5: DC +24V
- 6: 0V

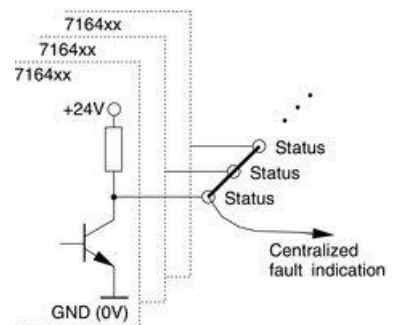
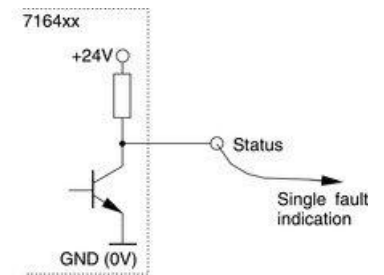

LED Status, Button, Rotary Switch

LED green	ON	Function is OK*
LED green, flashing 1 Hz	Overload	Load above 90 % of I nominal
LED green, flashing 5 Hz	Overload	Load above 100 % of I nominal
LED red	OFF	Module switched off or acknowledged*
LED red, flashing 1 Hz	Overload	Output off due to overload/short circuit*
LED red, flashing 5 Hz	Error	Wiring error – feedback (internal error)
LED red, flashing shortly	OFF	Output off via remote set/reset
LED red/green, flashing 1 Hz	ON	Target settings via rotary switch deviate from actual settings. NOTICE: Switching off and on via pushbutton required.
Button ***	ON/OFF	Nominal operation: ON/OFF Load monitoring tripped: 1st push: acknowledge 2nd push: ON
Rotary Switch (I) – Switch Position**		Rated current, see page 4.
Rotary Switch (C) – Switch Position**		Characteristic: 1: fast 2: middle 3: slow-1 4: slow-2 5: slow-3

* If the operating voltage is switched off, the last status is saved (Default).
** Accept the setting - after switching on again via the button, not by Remote Set/Reset
*** Master function - switch off via push button, can only be switched on again via push button

For further information see also the operating instructions