



ELECTROMEN - EM-339-PLI

Parallel drive for 2 x DC motors 12-24 V dc,
 2x10A

EM-339-PLI

Parallel drive for 2 x DC motors 12-24 V dc, 2x10A,
 pulse FB



- 12-24Vdc, 2x10A continuous, 2x20A 25% duty
- Synchronized parallel driving
- Operates with pulse feedback from motors
- Homing cycle & end of travel limits set by pulse counting
- Programmable with wide range of motor control functions

PRODUCT DESCRIPTION

The EM-339-PLI drive has been designed for driving two 12-24Vdc actuators or motors in parallel synchronisation.

The synchronisation is achieved by comparing 2-channel quadrature pulse feedback (max freq input 700Hz per channel) from each motor. The drive will compensate small differences by adjusting the motor speeds & if synchronisation can still not be achieved the drive will stop the motors to avoid any potential mechanical problems. The homing routine function is to reset/balance pulse counts.

In a compact 78 x 73 x 25mm package, the drive can provide up to 2 x 10A continuous current (@ 2KHz PWM freq setting). Din rail kits are available for mounting inside a control panel.

With up to 24 settable parameters via the EM-236 plug in module or EM-268 USB connection with Ementool PC software, it is a fully programmable cost effective solution for many applications. For volume projects a fully factory customised solution can be provide to suit customer specific requirements.

Key features

- Four quadrant – Speed, direction, acceleration/deceleration and braking control
- End of travel limits – Pulse counting or limit switch input
- Current and temperature limiting – For protection against overload
- Auto-reverse – Anti-trap safety function upon current limit activation
- Brake output – 2A output for releasing magnetic brakes
- Fault output & on board LED – To identify fault conditions

TECHNICAL DATA

Analogue input	0-5V, 0-10V or 4...20mA
Control type	Speed, Braking, Direction, Torque, Position, Soft start / stop
Current setting range	1-25 A
Dimensions length x width x height	78x73x25mm mm
Logic input high	>4V = ON
Logic input low	<1V = OFF
Max continuous current	2x10 A
Mounting	DIN rail
Operating temperature	-20°C...+60°C

Peak current	2x20 A
PWM frequency	2kHz/16kHz
Suitable engine	DC
Supplier	Electromen
Supply voltage	12 V DC, 24 V DC
Weight	110 g

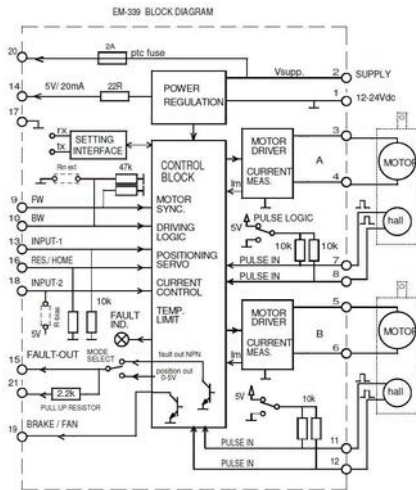

EM-339 WIRING EXAMPLES

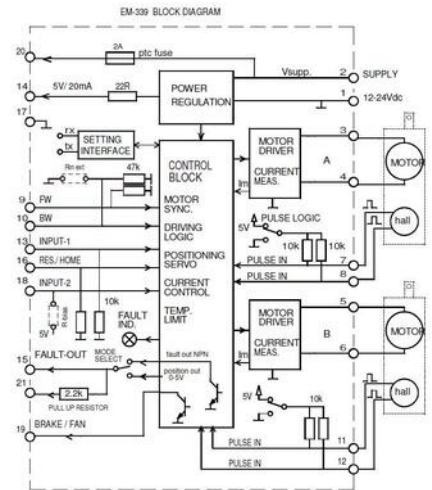
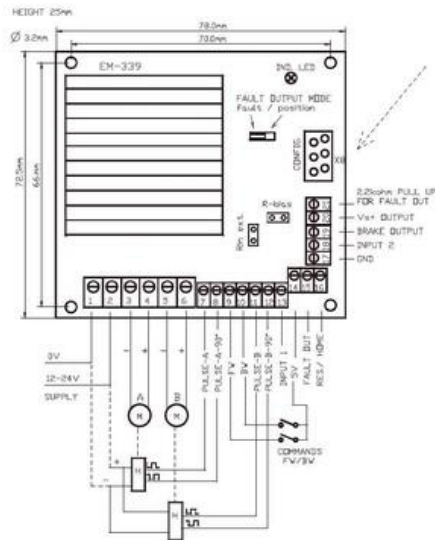

EM-339 WIRING EXAMPLES

